



200-CW SERIES

COLD FOOD DROP-IN WELL



- Coldwall drop-in refrigerated cold display pan.
- Meets NSF Std. #7 for cold holding at 41°F (5°C) or below.
- Exterior body is corrosion resistant steel.
- Interior fitted with drain at one end. Drain nipple with 3/4" thread supplied with gate valve.
- Insulated with CFC free, foamed in place polyurethane.
- Recessed, stainless steel ledge provided for supporting pans, adaptor bars included.
- Stainless steel top and coved corner interior.
- Dual air movement louver provided.
- Adjustable thermostat provides cold holding temperature flexibility.
- Condensing unit mounted on a swivel platform that allows for 90 degrees of rotation of intake/exhaust louver, giving the customer the option of mounting the louver on any of the counter four sides.

The 200-CW is a self-contained, wrapped coldwall drop-in refrigerated cold display pan with one piece stainless steel interior and top. 1" (25mm) drain with 3/4" thread, and gate valve provided. R-404a refrigerant, "CFC" free. Wrapped refrigeration construction, expansion valve, and adjustable thermostatic control. Entire system is mounted on corrosion resistant framework, suspended below unit body. Sliding shroud and dual air movement louver included to direct air flow.

The unit holds two (2) 6" (176mm) deep full-size pans or a combination of standard (gastronorm) pan sizes. The cold well includes three (3) 20" (508mm) pan divider bars.

- MODEL 200-CW:** refrigerated unit for cold display without ice, self-contained 1/4 hp compressor
- MODEL 200-CW/R:** refrigerated unit for cold display without ice, for use with a remote compressor



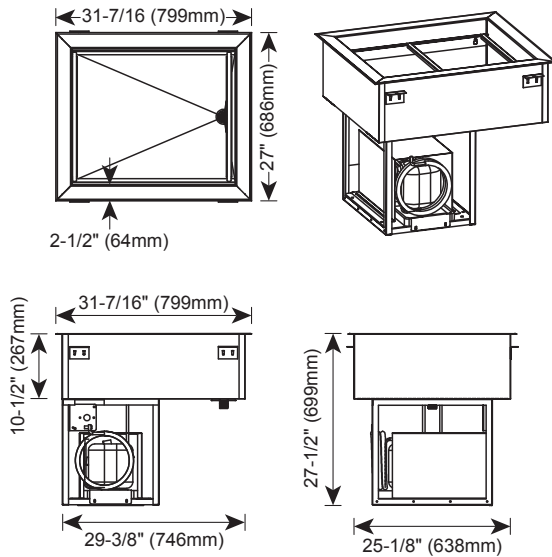

OPTIONS & ACCESSORIES

PAN DIVIDER BARS

12" (305mm) for Half-Size / Third-Size pans 1014395

REMOTE ON/OFF SWITCH SW-35840

8' (2438mm) Extension,

cutout (h x w): Contact Factory

200-CW DIMENSIONS: H X W X D

EXTERIOR:

27-1/2" x 31-7/16" x 27" (699mm x 798mm x 686mm)

INTERIOR COLD WELL:

6-1/4" x 26-7/16" x 22" (159mm x 671mm x 559mm)

COUNTER CUTOUT (L X W):

29-7/8" x 25-1/2" (759mm x 648mm)

DUAL AIR MOVEMENT LOUVER CUTOUT (H X W):

21" x 16" (533mm x 406mm)

PRODUCT/PAN CAPACITY (BASED ON 6" DEEP PANS)

72 lb (32.6 kg)

MAX. VOLUME: 44 qt. (42 L)

FULL-SIZE PANS*: Two (2) 12" x 20" x 6"

GN 1/1 (325mm x 530mm x 176mm)

HALF-SIZE PANS*: Four (4) 12" x 10" x 6"

GN 1/2 (325mm x 265mm x 176mm)

THIRD-SIZE PANS*: Six (6) 12" x 6" x 6"

GN 1/3 (325mm x 176mm x 176mm)

*WILL ALSO ACCEPT 2-1/2" (65mm) & 4" (102mm) DEEP PANS

WEIGHT	200-CW	200-CW/R
NET WEIGHT:	170 lb (77 kg) est.	Contact Factory
SHIP WEIGHT:	220 lb (100 kg)	Contact Factory
CRATE DIMENSIONS: (L X W X H)	36-1/2" x 32" x 36-1/2" (927 x 813 x 927 mm)	Contact Factory

ELECTRICAL

VOLTAGE	PHASE	CYCLE/HZ	AMPS	kW	PLUG CONFIG.
115	1	60	5.0	.6	 NEMA 5-15P 15A-125V PLUG 9' (229mm) LONG CORD

INSTALLATION REQUIREMENTS

Counter top material must be water resistant.

Distance of 3/4" (19mm) or more between top rims of wells to ensure easy cleaning.

Must be installed level.

Must not be installed in any area where it may be directly affected by steam, grease, dripping water, high temperatures, or any other severely adverse conditions.

Must not be installed under a hood.

Avoid installation under a 4-way ceiling diffuser.

Outdoor use is not recommended.

Drain or catch basin is required.

LED lighting is recommended for overhead lighting

CLEARANCE REQUIREMENTS

4" (102mm) in front of dual air movement louver

REMOTE BTU REQUIREMENTS

LOW TEMP COMPRESSOR: -10F SUCTION LINE

**BTU LOAD: 474

**DOES NOT INCLUDE LINE RUN FOR REMOTE COMPRESSOR